

GLOBAL JOURNAL OF ENGINEERING SCIENCE AND RESEARCHES RENEWABLE ENERGY BASED WATER PUMPING SYSTEM

Ginu Lawrence^{*1} & Dr. S. Swapna Kumar²

ABSTRACT

Human civilization has become modern and electrical power consumption greater in all industries and household equipments. The cost and requirement of all energy sources is increased but its availability decreases day by day. Solar energy can be easily converted to electrical energy by using the photovoltaic panel. Water pumping system has an important role in daily life which mainly depends on the electricity and the fossil fuels. So a simple and efficient photovoltaic panel based water pumping system is designed and implemented. The efficiency of the photovoltaic panel can be increased by using a proper Maximum Power Point Tracking (MPPT) algorithm with buck boost converter which will continuously check the voltage and current from the solar panel and adjust the duty ratio of the pulse which is generated by the microcontroller. The energy from the panel is stored in a battery and converted to ac voltage using an inverter circuit followed by the water pump. This system provides a cost effective, efficient and maintenance free PV energized water pump.

Keywords: Photovoltaic panel, Maximum Power Point Tracking, Buck Boost Converter, Microcontroller.

I. INTRODUCTION

With the advancement of technology the use of electricity increases day by day with the increase of population. In India the water pumping systems are mainly depending on the electrical power and the diesel engine. Most of the electric energy production process takes place in power plants using non renewable energy sources, such as coal, natural gas or crude oil, which accounts for the gigantic amounts of greenhouse gases emitted daily in the Earth's atmosphere. It increases the popularity to renewable energy resources like solar, wind, hydro power, biomass and geothermal etc. Renewable energy is formed by natural processes that are reloaded constantly. Most renewable energy comes either directly or indirectly from the sun. The use of renewable energy source reduce environmental pollution such as air pollution caused by burning of fossil fuels and improve public health, reduce premature mortalities due to pollution and save associated health costs. Based on REN21's 2017 report, renewable contributed 19.3% to humans' global energy consumption and 24.5% to their generation of electricity in 2015 and 2016, respectively. This energy consumption is divided as 8.9% coming from traditional biomass, 4.2% as heat energy (modern biomass, geothermal and solar heat), 3.9% hydro electricity and 2.2% is electricity from wind, solar, geothermal, and biomass. Worldwide investments in renewable technologies amounted to more than 286 billion dollars in 2015, with countries such as China and the United States heavily investing in wind, hydro, solar and biofuels [1]. Globally, there are an estimated 7.7 million jobs associated with the renewable energy industries, with solar photovoltaics being the largest renewable employer. As of 2015 worldwide, more than half of all new electricity capacity installed was renewable[2].

A. Photo voltaic technology

Solar photovoltaic (PV) devices, or solar cells, change sunlight directly into electricity. Photovoltaic (PV) technology is seen as technology of the future for generation of distributed low-power electricity. Solar PV has specific advantages as an energy source: once installed, its operation generates no pollution and no greenhouse gas emissions, it shows simple scalability in respect of power needs and silicon has large availability in the Earth's crust[3]. By using the photovoltaic panel the solar energy can be converted to electrical energy through photovoltaic effect. The panel will capture the sunlight as photon and it will begin to release the electrons. The negative and positive conductors create a pathway for the electrons and an electric current is created. This electric current is sent to wires that capture the electricity.

B. Maximum power point tracking (mppt)

Maximum power point tracking (MPPT) is a technique used with photovoltaic (PV) solar systems to maximize power extraction under all conditions. As the amount of sunlight varies, the load characteristic that gives the highest power transfer efficiency changes, so that the efficiency of the system is optimized when the load characteristic changes to keep the power transfer at highest efficiency. This load characteristic is called the maximum power point (MPP) and MPPT is the process of finding this point and keeping the load characteristic there.

Solar cells have a complex relationship between temperature and total resistance that produces a non-linear output efficiency which can be analyzed based on the I-V curve. It is the purpose of the MPPT system to sample the output of the PV cells and apply the proper resistance (load) to obtain maximum power for any given environmental conditions. MPPT devices are typically integrated into an electric power converter system that provides voltage or current conversion, filtering, and regulation for driving various loads, including power grids, batteries, or motors. The maximum power is generated by the solar cell at a point of the current-voltage characteristic where the product VI is maximum. This point is known as the MPP and is unique.

C. Photovoltaic water pumping system

Photovoltaic water pumping (PVWP) systems represent a feasible and renewable solution to support, and promote the sustainable management of the water resources, and the development of the agricultural sector [4]. Solar water pump is a type of water pumping system that works wherever there is abundant supply of sunlight. There are lack of researches of portable solar water pump which is used both irrigation and household water supply purpose. In many studies, battery is used recently for store energy which is produced by solar panel. Life time of battery is short and cost is high. So, cost and complexity of solar water pumping system is increased and farmers are less benefited. A typical solar powered pump- ing system consists of a solar panel array that powers an electric motor, which drives a pump is proposed, designed and implemented.

II. RELATEDWORKS

Solar photovoltaic water pumping system (SPVWPS) has been a promising area of research for more than 50 years. SPVWPS consists of different components and parts associated with different fields of engineering like mechanical, electrical, electronics, computer, control and civil engineering. The interdisciplinary nature of the system attracted there searchers, in the past, from all these fields of engineering and has been contributed by them to make the system more efficient and cost-effective to meet water-pumping needs of human, livestock and irrigation. The detailed literature available suggests that there search work on SPVWPS is not confined to any particular field of engineering[5].

The first case of solar PV water pump reported in 1964 in the Soviet Union. However, the flow rate and working head of the water-pumping systems were small, but these studies finally proved milestones in the development of future solar operated water pumping system. A comprehensive look at PV-powered water pumping systems from conceptualization to design and implementation is presented in the paper “Photovoltaic-Powered Water Pumping- Design, and Implementation: Case Studies in Wyoming” by Chowdhury BadruH, Sadrul Ula, Kirk Stokes[6].

Some proposed pumping systems make use of photovoltaic panels as a source of energy for the direct drive of a DC motor coupled to a pump hydraulic. Mokeddem in the paper “Test and analysis of a photovoltaic dc-motor pumping system”[7] presents the results of tests carried out at the Algerian University of Science and Technology of Oran

(USTO), on a solar photovoltaic water pumping system. This comprises a 1.5 kWp PV array directly coupled to a DC motor and a centrifugal pump. The system was tested for its performance over a period of four months and for two static head configurations. Although the motor-pump efficiency did not exceed 30%, which is typical for directly-coupled photovoltaic pumping systems, such a system is clearly suitable for low head irrigation in remote areas not covered by the national electricity grid, and where access to water comes as first priority issue than access to technology. The use of DC motors is questionable, in view of the frequent need for replacement of brushes.

Chaurey et al. [8] investigated the performance of seven PV pumping systems under the meteorological conditions of India. They used 0.102m diameter submersible multistage centrifugal pump(CP) driven by three phase AC motor. They reported that the efficiency of all the PV pumping systems reduced at off design head conditions. All the multistage submersible CPs achieved maximum efficiency at designed parameters. The average daily water output was sufficient to meet the water demand of a typical Indian village. However, regular monitoring of subsystems was essential for its reliability.

Hamrouni et al. [9] performed theoretical and experimental investigation on the performance of standalone SPVWPS under the meteorological conditions of Tunisia. They used solar radiation and ambient temperature as input to simulate the results. They reported that under constant solar irradiance, PV generator output and pump flow rate depended significantly on radiation. Moreover, the pumping performance characteristics degraded with the change in meteorological conditions. The experimental study showed the best performance of the water pump during midday. Also, the theoretical and experimental results were in good agreement.

Lujara et al. [10] investigated the performance of photovoltaic water pumping system with and without MPPT using two different types of DC motor drive systems. The first system consisted of a PMDC motor, PV array and a progressive cavity pump. The DC-DC converter as MPPT, was interfaced between the PV array and the motor. The second system, in addition to the PV array and pump, consisted of 2 - pole IM and PWM inverter. The investigation also aimed to select a suitable drive system to match the pumping load and to model the losses occurring in the components of photovoltaic water pumping system. Proper matching of drive system and load ensured maximum efficiency of PV pumps at a specific head. Modeling the losses ensured efficient utilization of pump power. They reported that SPVWPS based on PMDC motor.

Katan et al. [11] analyzed the performance of SPVWPS with MPPT, helical rotor pump and sun tracker. Simulation results were verified by theoretical and field test results. The helical rotor pump could use the different ranges of solar energy and had good efficiency at off rated speeds. It was reported that with MPPT, at the head of 5m, the flow rate was increased to 31.58 l/min from 12.77 l/min, which was a significant enhancement. Similarly, with the inclusion of sun tracker, solar energy received by a PV panel increased by 36%.

Roungsan Chairicharoen proposed the optimal solar energy control system for solving the problem of unstable power for multi-levels water tank in Control System for Synchronous Battery-less Solar-Powered Series Water Pumps[12]. The idea is to develop a series of products for small energy-saving irrigation such as the village water supply system to increase competitiveness. However, during testing equipment and systems planned to coincide with the rainy season, the operation is not easy to take place. Due to the unpredicted light intensity and clouds, the data collection is obscured by these uncontrolled conditions.

Yadunandana V, Chandasree Das proposed the paper Optimization of Solar Photovoltaic Water Pumping System during Monsoon Conditions[13]. In this study a BLDC motor is used for variable speed drive which gives better efficiency over induction motor drives and conventional brushed dc motors. The use of BLDC motor is very efficient in this context. In this study the system is using without battery, so there will be issues when it used in rainy season and also at night conditions.

The research on the topic solar photovoltaic based water pumping system is continuous today, due to the reduction of the fossil fuels and electricity. To improve the solar panel efficiency and to get the maximum power from the sun there are several methods that are included in the review.

III. SYSTEM METHODOLOGY

The main aim of the system is to pump water using the photovoltaic panel with greatest efficiency. The system consists of mainly two parts: charging section and the inverting section. In charging section for getting the maximum power from the photovoltaic panel use the MPPT algorithm with the buck boost converter. The DC is inverted to AC by using the inverter.

A. Block diagram

The block diagram of the system is shown in the figure 1. The block diagram mainly consists of photovoltaic panel, buck boost Converter with MPPT algorithm, Battery, Inverter circuit and the Water pump. The solar energy is converted by the solar PV array and the MPPT used for tracking the maximum power point. Buck boost converter is used as DC - DC Converter that will improve the gain and efficiency of the entire system. The battery will store the energy and the voltage will be converted to AC by using the inverter circuit. A water pump is placed followed by the inverter. A voltage divider circuit is connected to the photovoltaic panel and microcontroller. Another voltage divider circuit is connected to the battery and the microcontroller. A current sensor is connected in series with

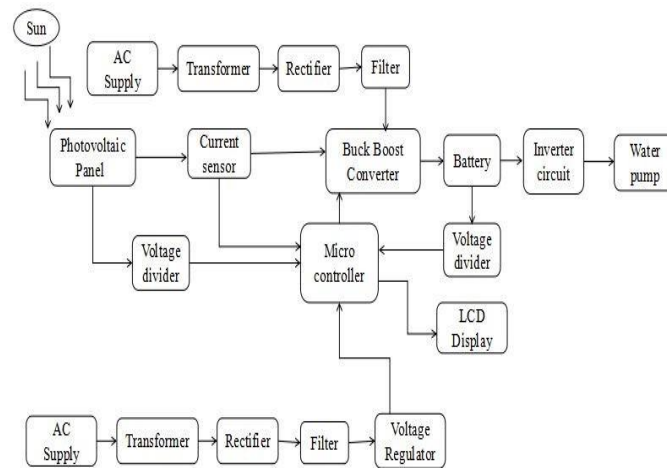

Fig. 1. Proposed Block Diagram of the Photovoltaic Panel Based Water Pumping System

the photovoltaic panel and the buck boost converter and given to the microcontroller. DC Power supply is made by using the blocks of transformer, rectifier circuit and filter circuit. The power supply is used for powering the microcontroller and for giving the VCC to the mosfet driving circuit. An LCD display is used for showing the values of photovoltaic panel voltage, battery voltage, current, and the power of the system.

B. Circuit diagram

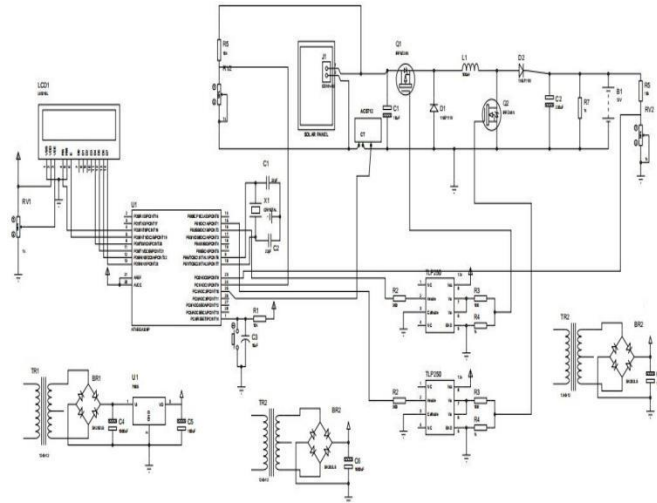

Fig. 2. Circuit Diagram of the Charging Section of Photovoltaic Panel Based Water Pumping System

The circuit diagram of the Charging section is shown in the figure 2. The circuit consists of buck boost converter, microcontroller, MOSFET driving circuit, voltage divider circuit and power supply circuit. The photovoltaic panel voltage is given to the input of the buck boost converter and it will give the maximum power in the output. The microcontroller is used for giving the pulse to the switches by comparing the input and the reference voltage. The MPPT algorithm is used for getting the maximum power from the photovoltaic panel. The output of the buck boost converter is given to the battery for storing the charge.

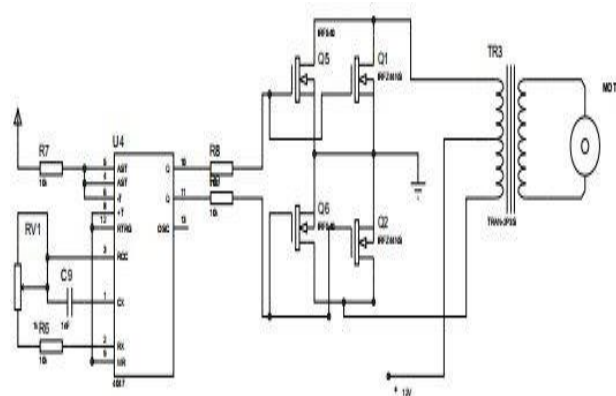

Fig. 3. Circuit Diagram of the Inverter Section of Photovoltaic Panel Based Water Pumping System

The circuit diagram for the inverter is shown in figure 3. The input of the circuit is from the battery and the output is given to the water pump. The core of the circuit is CD4047 chip. This chip acts as an Astable Multivibrator. It generates clock pulses of frequency 50Hz. These pulses are taken to N- MOSFET to drive the transformer. The transformer steps up the 12V to 230V. So every time a pulse reaches the MOSFET gate, there will be a 220V half cycle at the output. In the next pulse, the second MOSFET triggers for the second half cycle of 220V. So with two MOSFETS turning on and off at 50Hz frequency, there will be 50Hz 220V cycle output at the transformer end.

IV. SYSTEM IMPLEMENTATION

A photovoltaic panel based water pumping system is designed and implemented and it is shown in the figure:4.

A photovoltaic panel of 20watt power rating is connected with an ACS712 current sensor module of 5A maximum current and with voltage divider. These are connected with the microcontroller ATmega328 for measuring the input current and voltage from panel. Panel is also connected with buck boost converter, which will regulate the panel voltage using MPPT algorithm. The microcontroller will generate pulses according to the input voltage. The pulses from the microcontroller to the MOSFET IRFZ44 is amplified by using MOSFET driver circuit. TLP250 is used as MOSFET driver IC.

A 7.5Ah, 12V rechargeable battery is used for storing charge. A 200watt inverter is needed for running a 40watt, 230V AC submersible pump. The inverter is designed and implemented using a stable multivibrator IC CD4047 and IRFZ44 n channel MOSFET connections

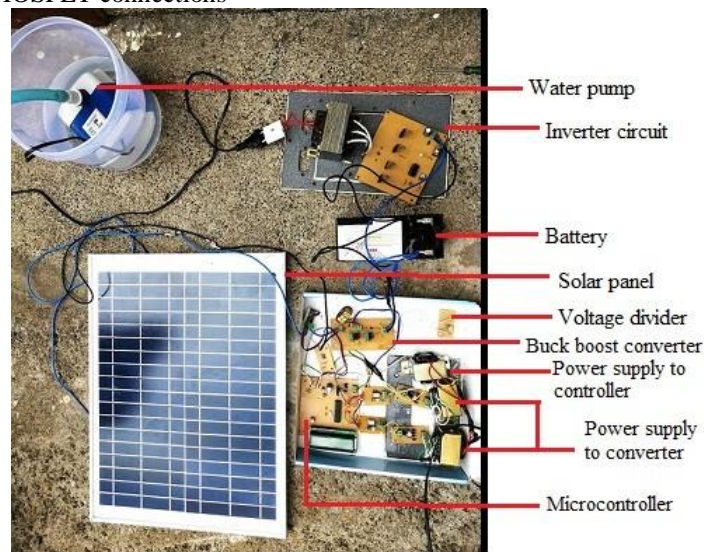

Fig. 4. Experimental Setup of proposed system

V. RESULTS OF IMPLEMENTATION

The proposed system for pumping water using photovoltaic panel is implemented and several experiments are done on the different parts of the system with different conditions.

A. Study of photo voltaic panel voltage with time in a day

In this study the photovoltaic panel is placed openly in the sunlight and the voltage is measured by using the digital multimeter at different time in a day. The open circuit voltage V_{oc} at different time is obtained in this study. Figure 5 shows the solar panel voltage at different time instances. The solar panel voltage is changing with different weather conditions. High voltage is getting at the time between 11 am to 2pm. The photovoltaic panel voltage depends on the intensity of sunlight. When the intensity of sunlight increases, the open circuit voltage also increases.

B. Study of photo voltaic panel voltage with and without load

The photovoltaic panel open circuit voltage is measured and then it is connected to the load and the panel voltage is measured and noted. The photovoltaic panel gives the maximum voltage when it is not connected to the load, because there is no current flow through it and the impedance is infinity. When the load is connected with the panel there is a continuous path for current and there will be impedance. So the voltage drop occurs when the panel is

connected to the load, it will decrease the voltage and reduce the efficiency of the entire system. Figure 6 shows the graph of panel voltage without load vs panel voltage with load.

C. Study of photovoltaic panel voltage with MPPT Charge controller

The maximum power point tracking algorithm is used in this system for improving the efficiency of the solar water pumping system. The solar panel will not give the same voltage when

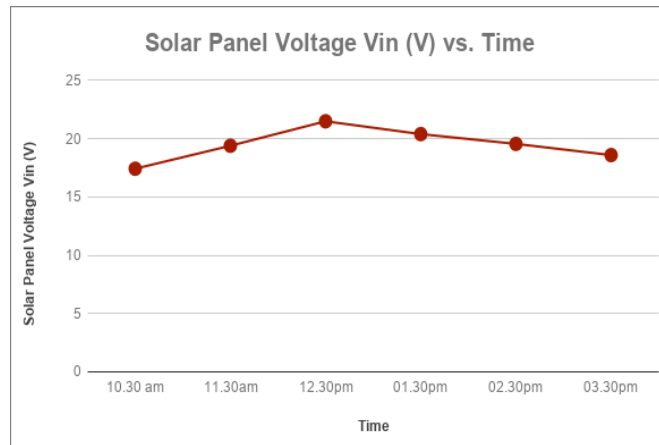

Fig. 5. photovoltaic panel voltage at different time in a day

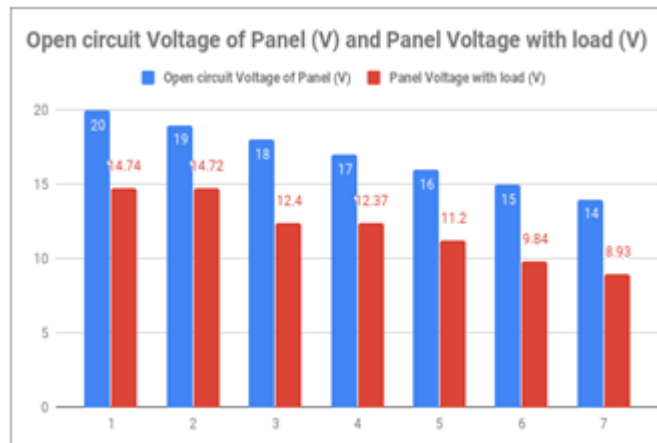

Fig. 6. Plot of panel voltage without load vs panel voltage with load

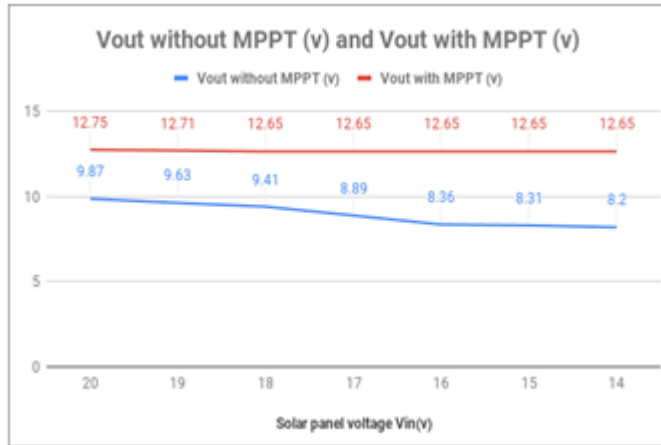

Fig. 7. Plot of comparison of Panel voltage and Output voltage of buck boost converter with and without using MPPT

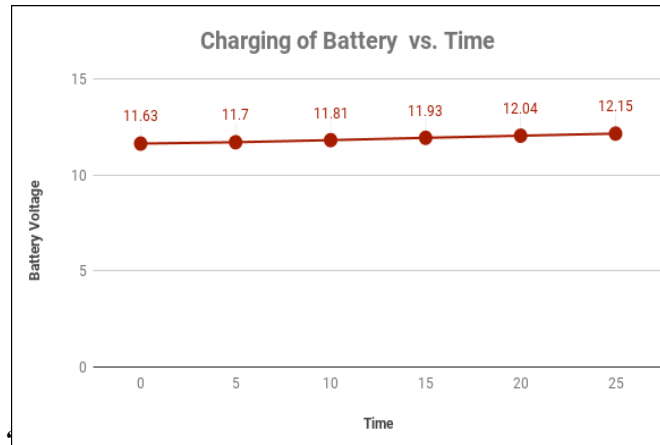

Fig. 8. Plot of Charging of Battery with respect to charging time

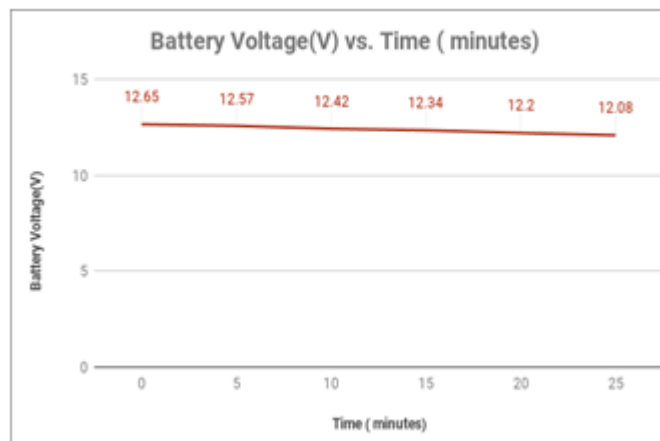

Fig. 9. Plot of Battery voltage with respect to pump running time

it connected to a load. There will be decrease in voltage and it will reduce the efficiency of the entire system. The output of buck boost converter is low and also varies when it not using MPPT algorithm. The buck boost converter will gives the proper voltage which is required for the battery and gives a regulated voltage when we uses the MPPT algorithm. The Figure 7 shows the different open circuit voltage values of solar panel and the voltage values with connected load without using the MPPT algorithm.

D. Study of Battery voltage with respect to battery charging time

The battery is charged by using the photovoltaic panel with MPPT algorithm and buck boost converter. The battery will charge with time. The charging time required to charge the rechargeable battery is measured and noted. The figure 8 shows the values obtained in the measurement. The rate of charging of battery will increases with increase the sunlight since more voltage will get at that time. The rechargeable battery is charged and the time taken to increase 1V is nearly 30 minutes. The battery will charge fully in 2-3 hours by using the system. If the intensity of sunlight remain constant with full intensity the time required to charge will decrease.

E. Study of Battery voltage with respect to pump running time

The complete system of water pump using the photovoltaic panel is took under test. The voltage of battery is measured before running the pump. Then the pump is made switch ON . Every 5 minutes the value of battery voltage is measured and noted. The values obtained are plotted in figure 9.

VI. CONCLUSION

The renewable energy based water pumping system is designed, implemented and made an analysis using MPPT algorithm and buck boost converter. The various time open circuit voltage are measured and the solar energy is higher at 11am to 2pm. The panel voltage depends on the intensity of sunlight so the output voltage of solar panel is varied in accordance with the weather. When the panel is used without using the MPPT algorithm and buck boost converter the output voltage is very less and insufficient to charge the battery in effective way. The Output of the buck boost converter is stable when using the MPPT algorithm and the charging of battery occurred fastly. The output of the buck boost converter is varies and very less when without using MPPT algorithm. So when we use the MPPT algorithm with the buck boost converter we get more efficient water pumping system. The charging and discharging time of battery is also analysed. The water pump can be run with the battery back uptime of 1 hour.

VII. FUTURESCOPE

In the advanced technological world the need of energy is increases day by day. So there are several researches are doing with the renewable energy resources. In case of water pumping system the energy is more needed and now we depends on the deasel and electricity. Due its less availability wee need to change the dependency on that. So the renewable energy based water pumping system will very useful in future. There are many future scope based on this system.

The system can increase the power rating of water pump by replacing the solar panel with highest wattage. When the high power solar panel is used we can easily charge battery. The system can be made more usefull if we remove the dependency on the electricity. There is need to find a method for powering the microcontroller and the MOSFET driving circuit from panel. The solar tracking is another method to improve the efficiency of the system. The panel gets more energy from the sun since it is always face the sun. If we replace the battery with the super capcitor the charging time can be reduced. These are the future scope of the project.

REFERENCES

1. *Ernesto Macas Galn, "Renewables 2016 Global Status Report" ISBN 978-3-9818107-0-7,2016.*
2. *Vaughan and Adam, "Renewables made up half of net electricity capacity addedlastyear" viaTheGuardian,25,October2016.*

3. Lo Piano, Samuele; Mayumi and Kozo , “Toward an integrated assessment of the performance of photovoltaic power stations for electricity generation”. *Applied Energy*. 186 (2): 167-74. doi:10.1016/j.apenergy.2016.05.102, 2017.
4. Chowdhury Badrul H, Sadrul Ula and Kirk Stokes, “Photovoltaic-powered water pumping design, and implementation: case studies in Wyoming.” *IEEE Trans Energy Convers*;8(4):64652,2002.
5. Sontake, V. C. and Kalamkar, V. R., “Solar photovoltaic wter pumping system - a comprehensive review”. *Renewable and Sustainable Energy Reviews*, v. 59, p. 1038 1067,2016.
6. Chowdhury BadrulH, Sadrul Ula and Kirk Stokes,“ Photovoltaic-powered water pumping design, and implementation: case studies in Wyoming.” *IEEE Trans Energy Convers*;8(4):64652,2002.
7. Mokeddem, A. et al., “Test and analysis of a photovoltaic dc-motor pumping system.”In: *ICTON Mediterranean Winter Conference*,2007.
8. Chaurey A, Sadaphal PM and Tyaqi D., “Experiences with SPV water pumping systems for rural applications in India.” *Renew Energy* 1993; 3:961-4.,2015.
9. Hamrouni Nejib, Jraidi M and Cherif Adnene., *Theoretical and experi- mental analysis of the behaviour of a photovoltaic pumping system*. *Sol Energy*;83:1335-44,2009.
10. Lujara N K, VanWyk J D and Materu P N. “Loss models of photovoltaic water pumping systems”,In:*Proceedings of IEEE Africon*:2.p.965-70, 2004.
11. Katan RE, Agelidis VG and NayarCV. “Performance analysis of a solar water pumping system.” In: *Proceedings of power electronics, drives and energysystemsforindustrialgrowth*:18-11.p.81-87,2011.
12. Rounsan Chaisricharoen, Wanus Srimaharaj and Supansa Chaising “Control System for Synchronous Battery-less Solar-Powered Series Water Pumps”. 978-1-5386-4288-7/18/ IEEE,2018.
13. Yadunandana V and Chandasree Das . “Optimization of Solar Photo-voltaicWaterPumpingSystemduringMonsoonConditions”.978-1-4673- 9925-8/16/ IEEE,2016.